



Klasse *Label*

```
class Label {  
    Code code;  
    List<Integer> fixupList; // code positions to patch  
    int adr; // address of label in code  
  
    // inserts offset to label at current pc  
    void put ();  
  
    // defines label to be at the current pc position  
    void here ();  
}
```

Klasse *Operand* – Erweiterung für Sprünge



```
class Operand {  
    public enum Kind {  
        Con, Local, Static, Stack, Fld, Elem, Meth, Cond  
    }  
  
    public Kind kind;  
    public Struct type;  
    public int val;           // Con: value  
    public int adr;          // Local, Static, Fld, Meth: address  
    public Obj obj;          // Meth: method object from the symbol table  
  
    public CompOp op; // Cond: comparison operator  
    public Label tLabel; // Cond: target for true jumps  
    public Label fLabel; // Cond: target for false jumps  
}
```

Klasse Code – Erweiterung für Sprünge



```
class Code {  
    ...  
  
    // generates unconditional jump instruction to lab  
    void jump (Label lab);  
  
    // generates conditional jump instruction for true jump  
    // x represents the condition  
    void tJump (Operand x);  
  
    // generates conditional jump instruction for false jump  
    // x represents the condition  
    void fJump (Operand x);  
}
```

Klasse *Label* - Methode *put*

```
// inserts offset to label at current pc  
void put () {  
    if (isDefined()) {  
        code.put2(adr - (code.pc - 1));  
    }  
    else {  
        fixupList.add(code.pc);  
        // insert place holder  
        code.put2(0);  
    }  
}
```

Klasse *Label* - Methode *here*

// defines label to be at current pc

```
void here () {  
    if (isDefined()) {  
        // should never happen  
        throw new IllegalStateException("label defined twice");  
    }  
  
    for (int pos : fixupList) {  
        code.put2(pos, code.pc - (pos - 1));  
    }  
  
    fixupList = null;  
    adr = code.pc;  
}
```

Semantische Aktionen



```
Operand CondTerm () {  
    Operand x = CondFact();  
    while (sym == and) {  
        code.fJump(x);  
        scan();  
        Operand y = CondFact();  
        x.op = y.op;  
    }  
    return x;  
}
```

```
Ausschnitt aus Statement ()  
case if_  
    ...  
    Operand x = Condition();  
    code.fJump(x);  
    x.tLabel.here();  
    ...
```

```
Operand Condition () {  
    Operand x = CondTerm();  
    while (sym == or) {  
        code.tJump(x);  
        scan();  
        x.fLabel.here();  
        Operand y = CondTerm();  
        x.fLabel = y.fLabel;  
        x.op = y.op;  
    }  
    return x;  
}
```

Semantische Aktionen

Ausschnitt aus **Statement** ()

```
case while_  
    scan();  
    check(lpar);  
    Label top = new Label(code);  
    top.here();  
    Operand x = Condition();  
    code.fJump(x);  
    x.tLabel.here();  
    check(rpar);  
    Statement();  
    code.jump(top);  
    x.fLabel.here();
```



Für die Codeerzeugung von "break"
braucht Statement ein Label als
Parameter

Beispiel: Methoden & Methodenaufrufe



```
void m1 ()  
    char c;  
{...}
```

```
void m2 (int i)  
    int j;  
{...}
```

```
...  
void main () ... {  
    m1();  
    ...  
    m2(1);  
}
```

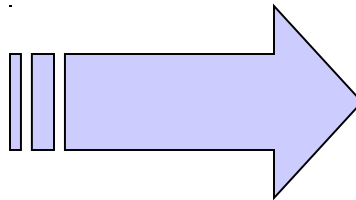

```
0: enter 0, 1  
3: ...  
...  
25: exit  
26: return  
27: enter 1, 2  
30: ...  
...  
61: exit  
62: return  
...  
167: call -167  
170: ...  
...  
228: call -201  
231: ...
```

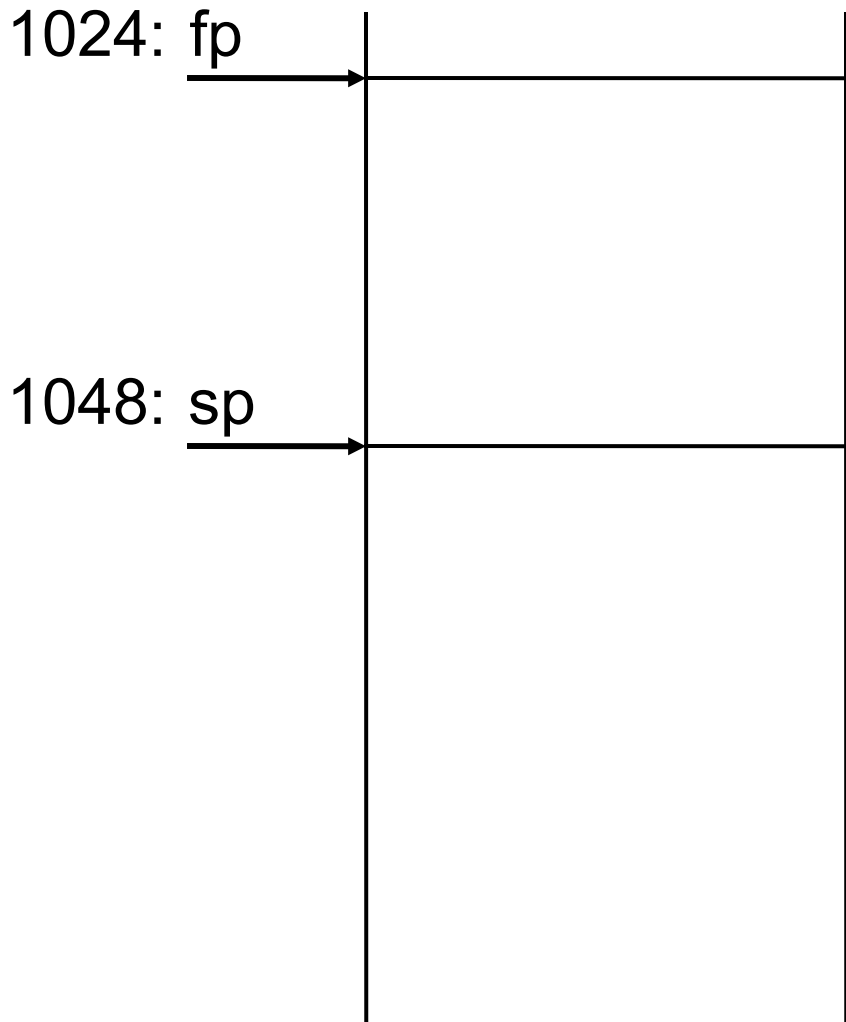

Methodenaufruf m1



```
0: enter 0, 1
3: ...
...
25: exit
26: return
27: enter 1, 2
30: ...
...
61: exit
62: return
...
167: call -167
170: ...
...
228: call -201
231: ...
```

pc →

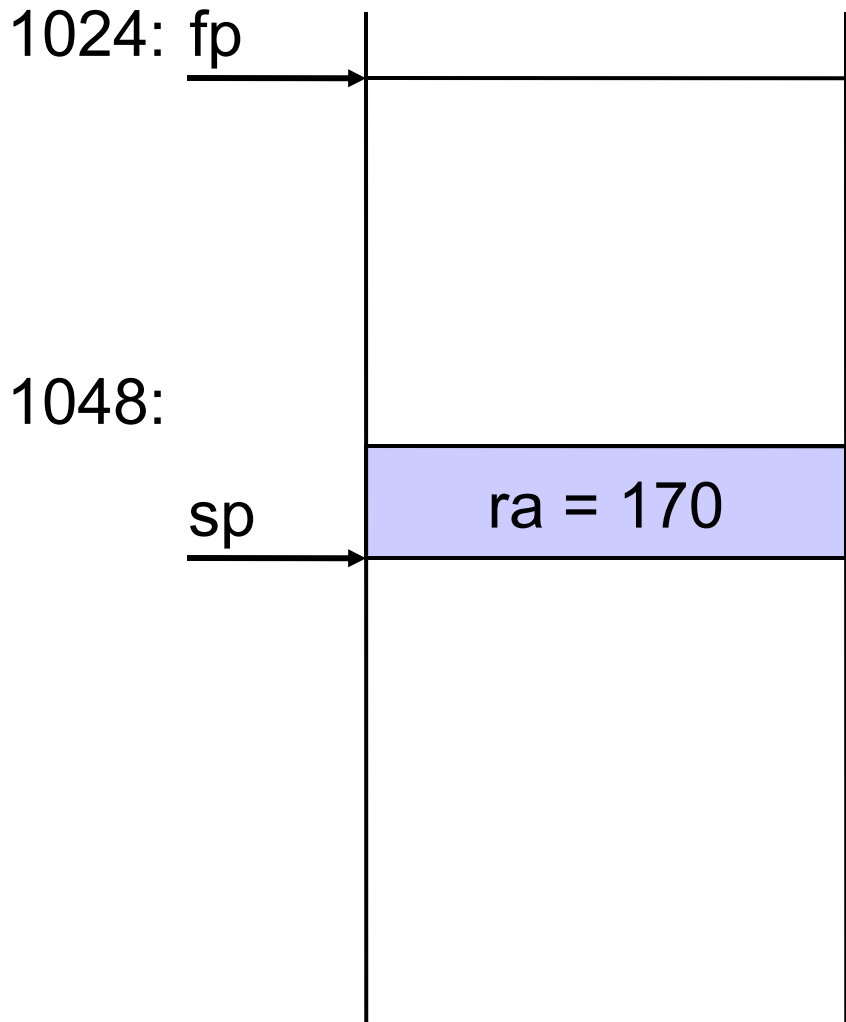
Methodenaufruf m1



```
0: enter 0, 1
3: ...
...
25: exit
26: return
27: enter 1, 2
30: ...
...
61: exit
62: return
...
167: call -167
170: ...
...
228: call -201
231: ...
```

pc

Einsprung in Methode m1

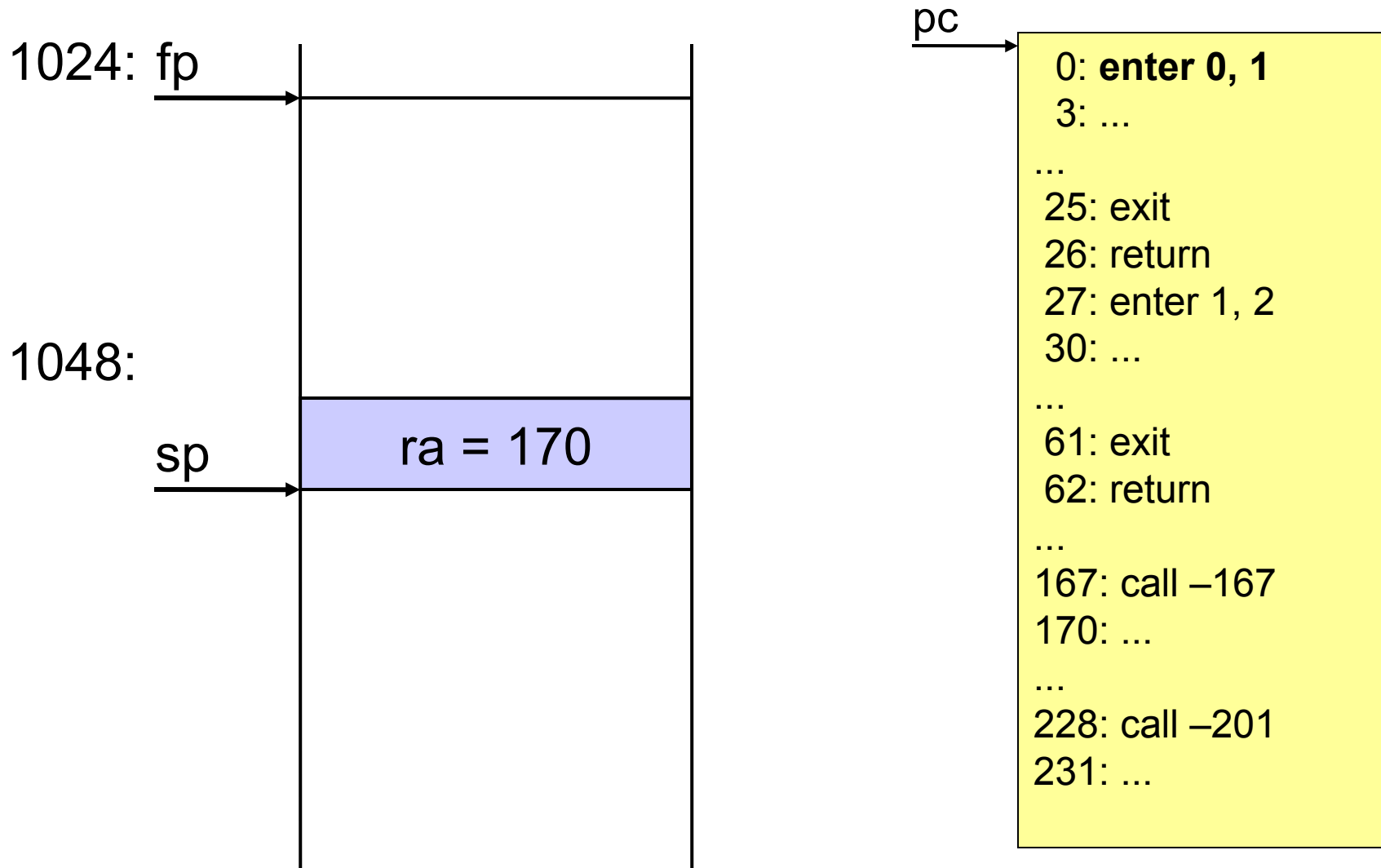

Einsprung in Methode m1

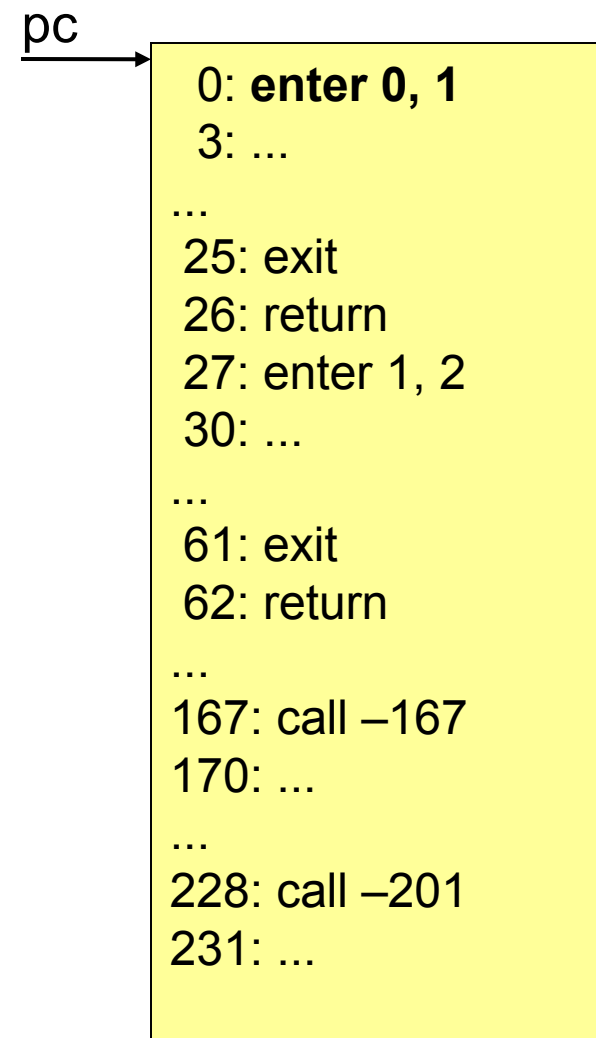
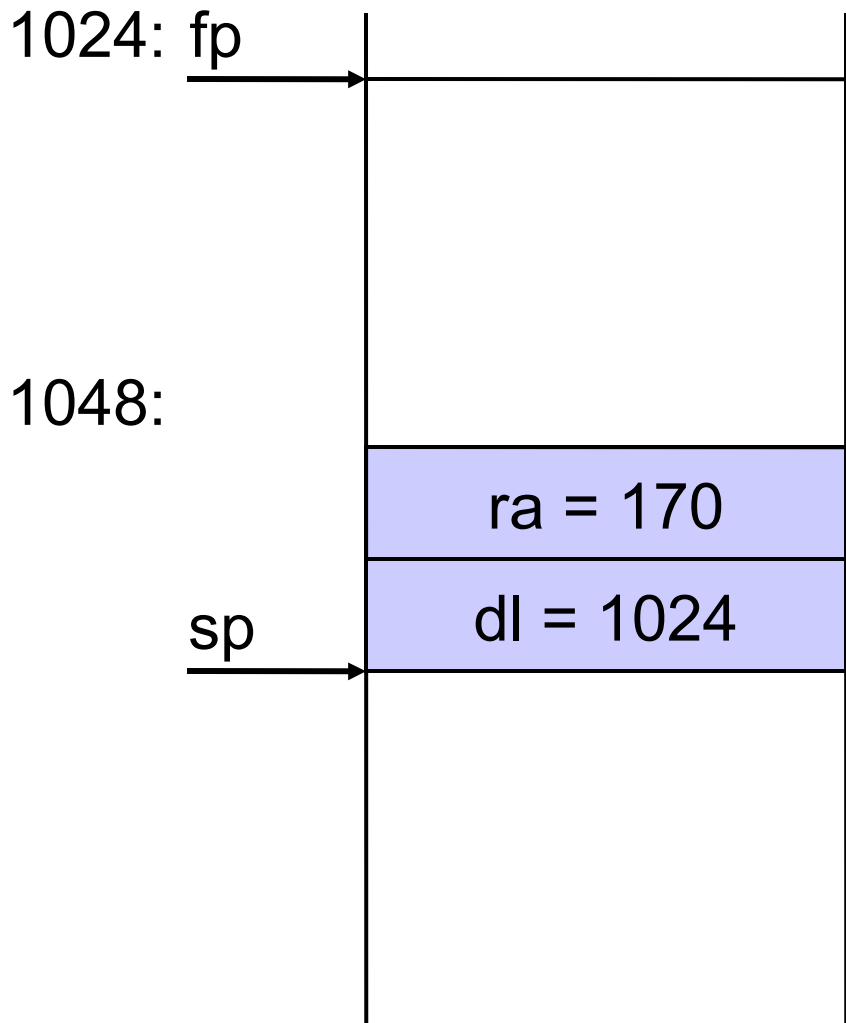

Einsprung in Methode m1

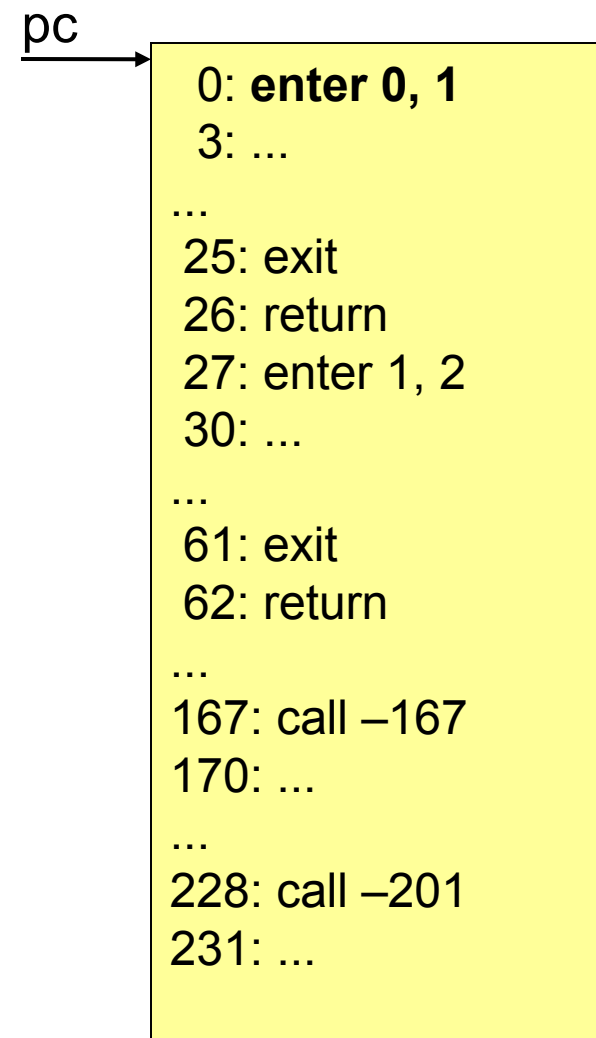
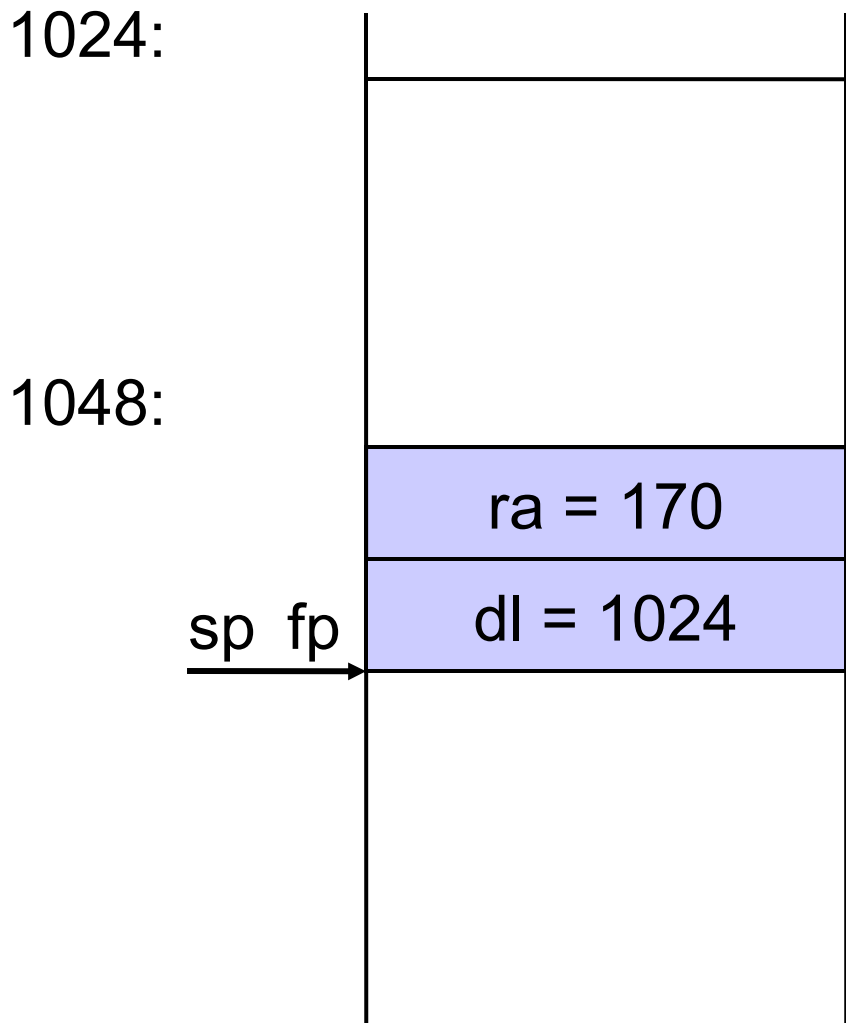

Einsprung in Methode m1

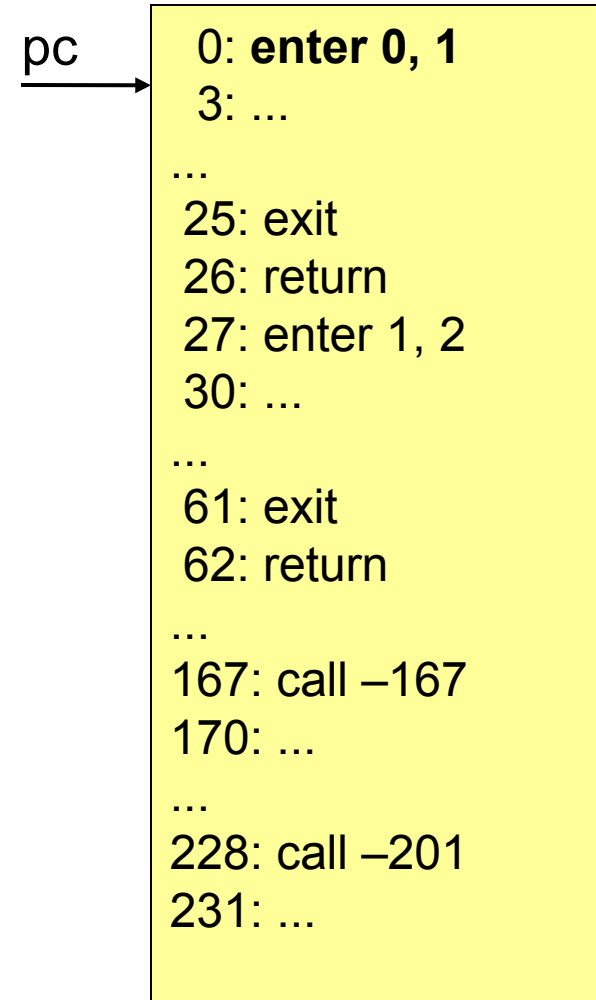
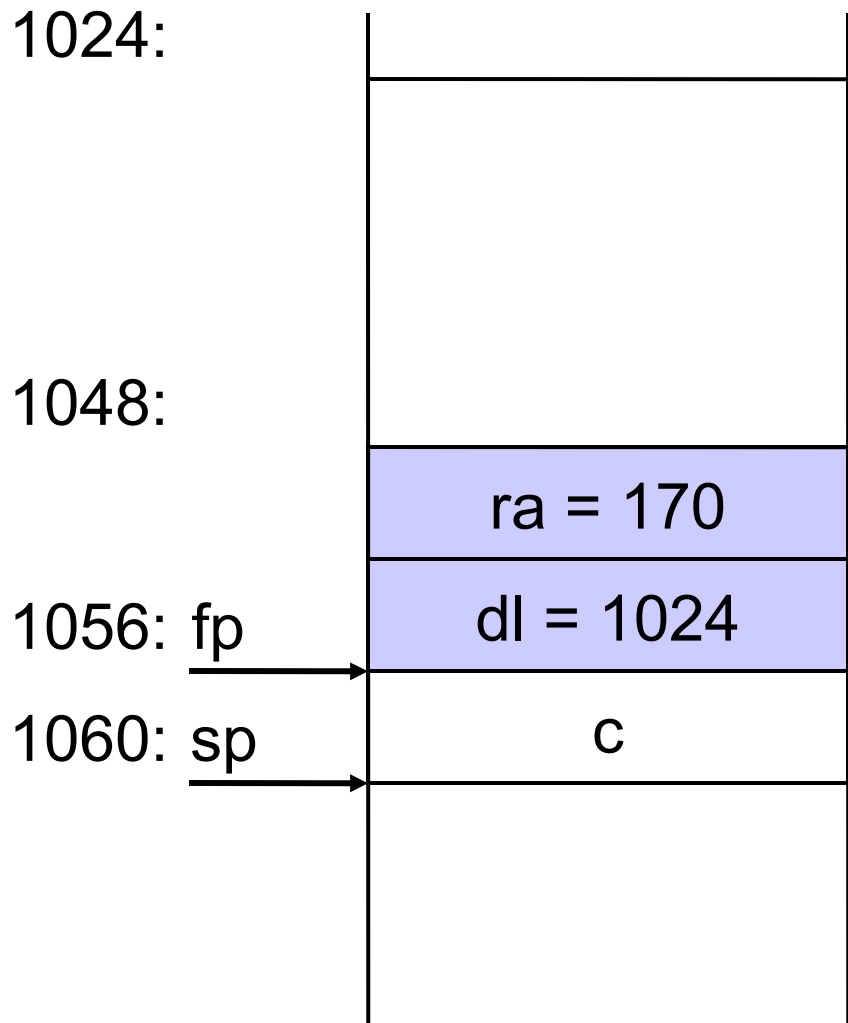

Ende der Methode m1

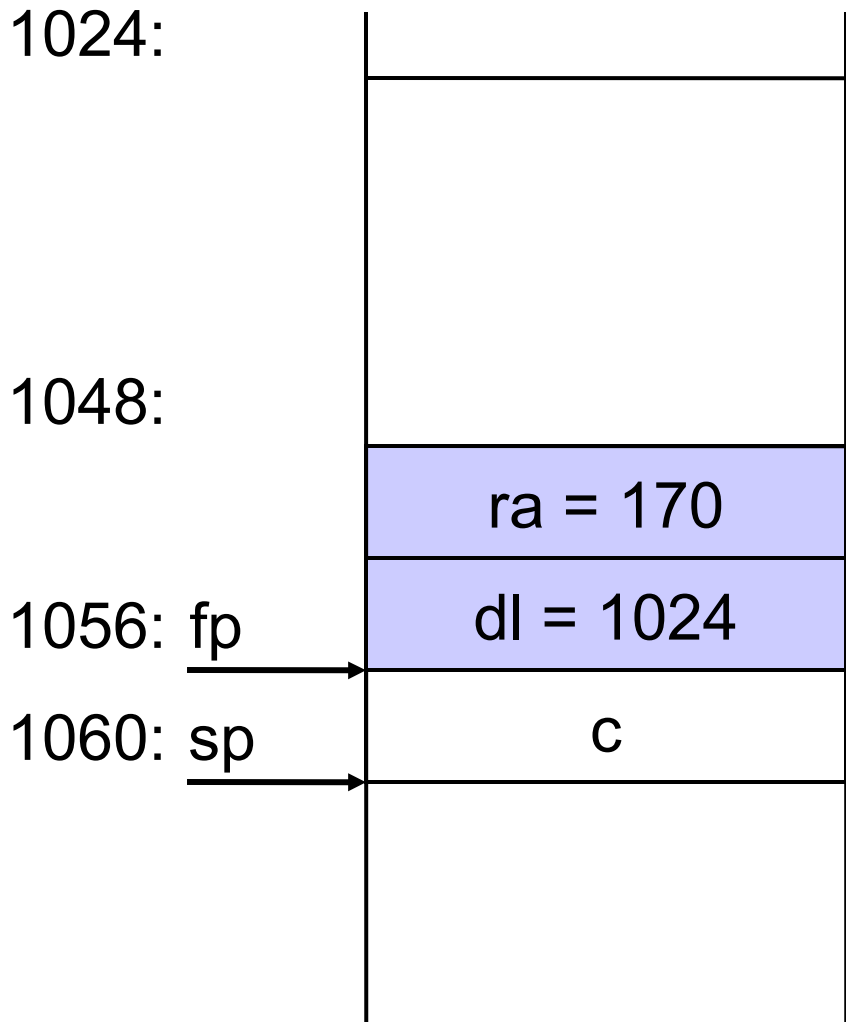

```
0: enter 0, 1
3: ...
...
25: exit
26: return
27: enter 1, 2
30: ...
...
61: exit
62: return
...
167: call -167
170: ...
...
228: call -201
231: ...
```

pc →

Ende der Methode m1

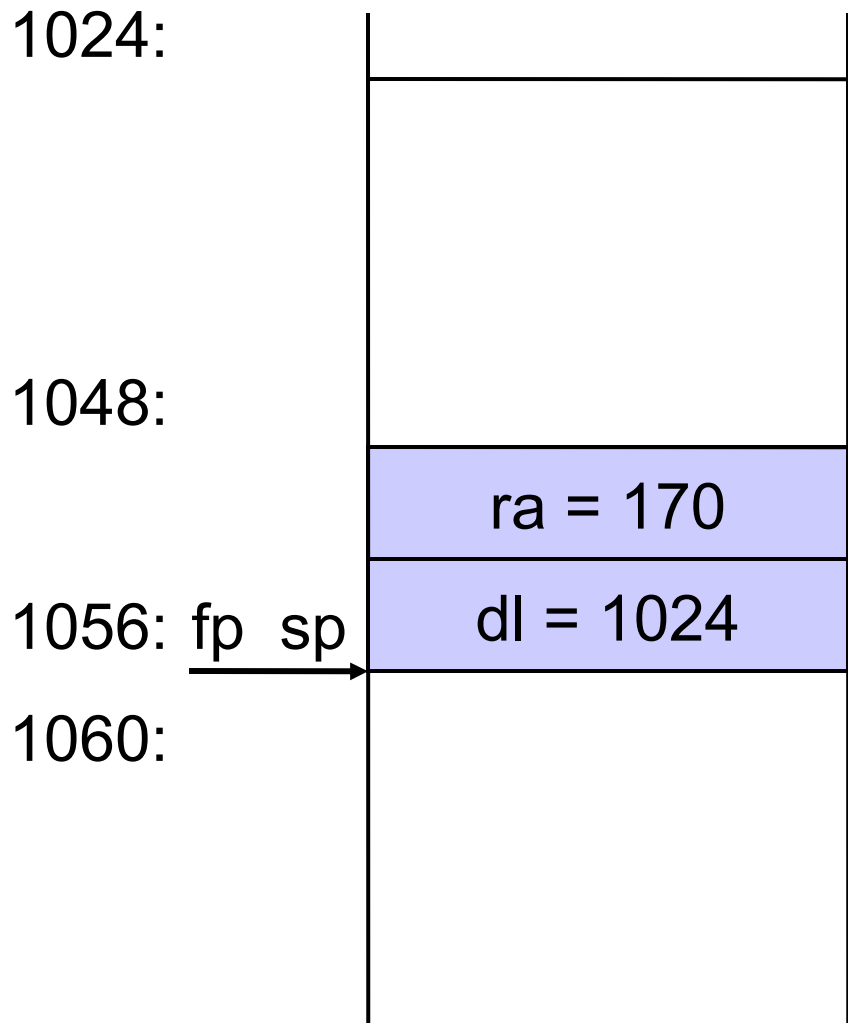

```
pc → ...
0: enter 0, 1
3: ...
...
25: exit
26: return
27: enter 1, 2
30: ...
...
61: exit
62: return
...
167: call -167
170: ...
...
228: call -201
231: ...
```

Rücksprung zum Rufer der Methode m1

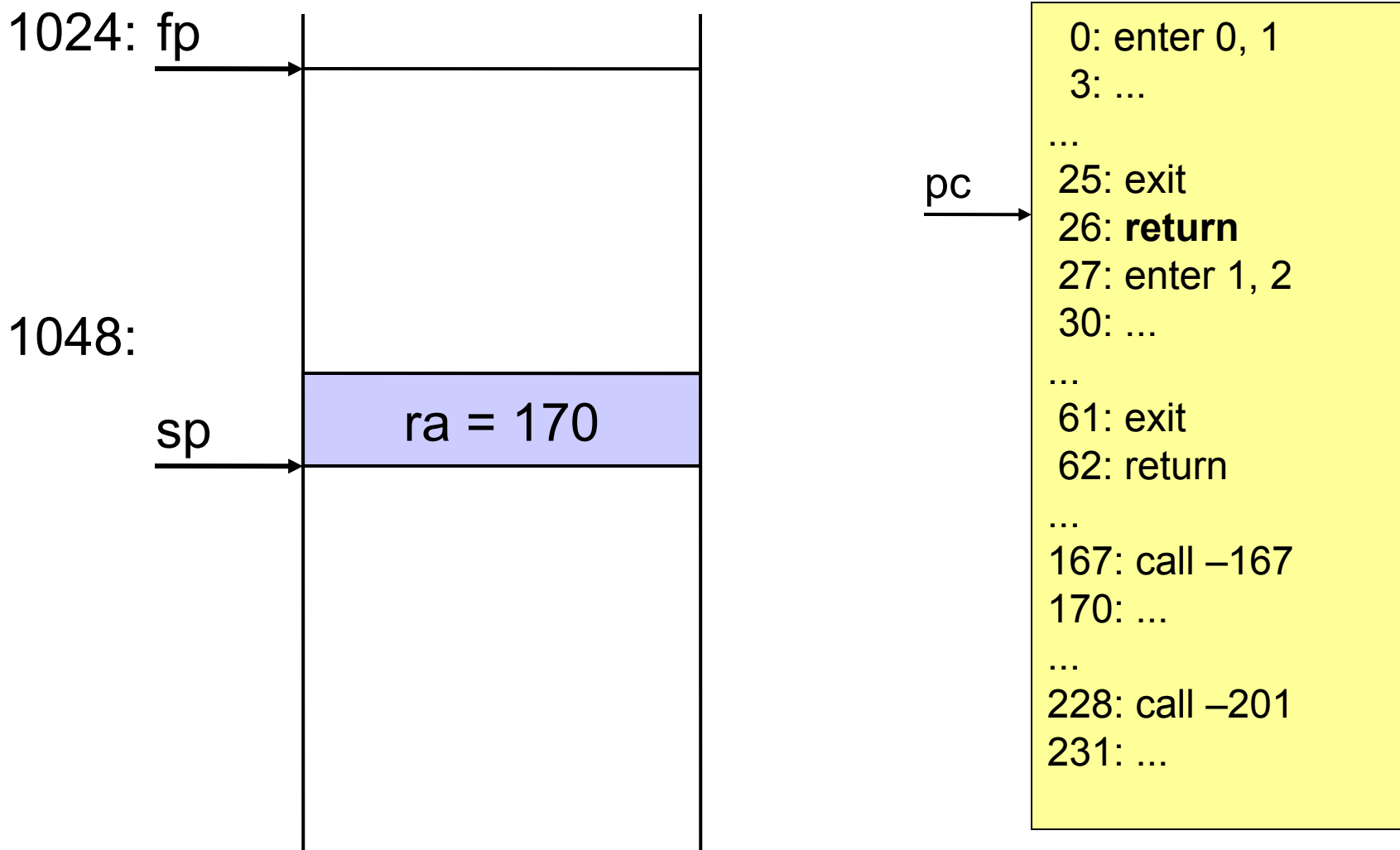

Rücksprung zum Rufer der Methode m1

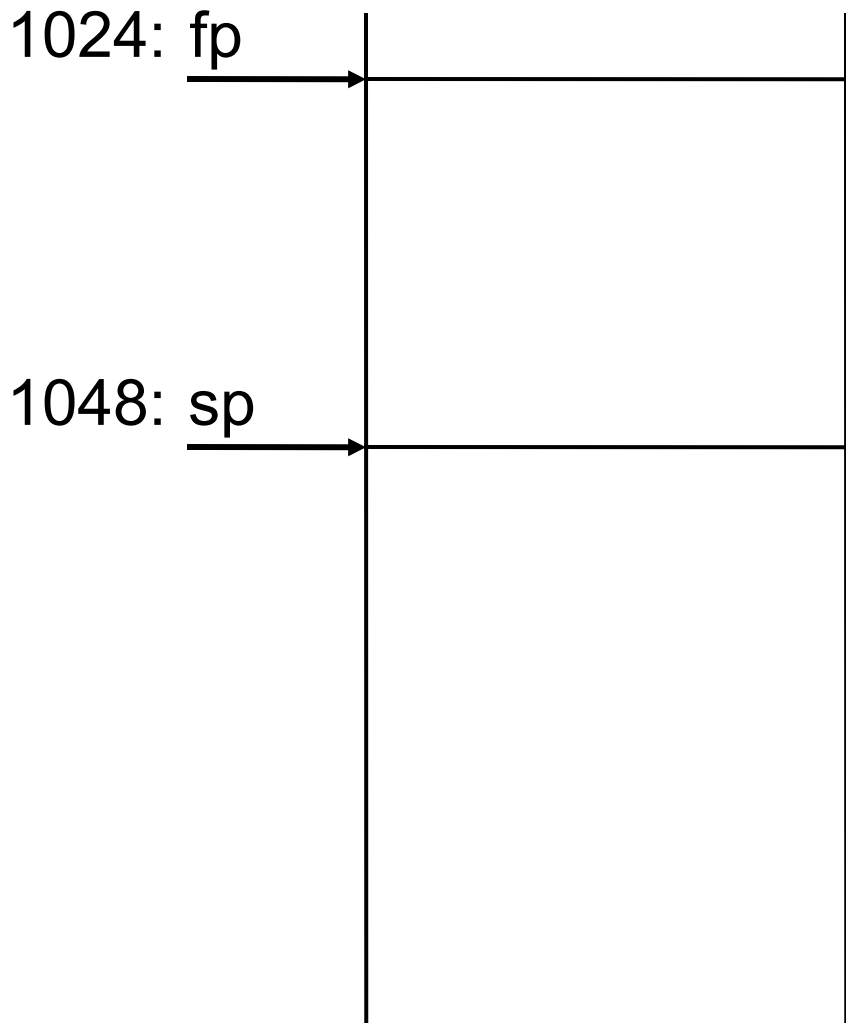

```
0: enter 0, 1
3: ...
...
25: exit
26: return
27: enter 1, 2
30: ...
...
61: exit
62: return
...
167: call -167
170: ...
...
228: call -201
231: ...
```

pc →